

Bevel Crank / Spring Retractable Twin Line Gas Welding Hose Reels



Series BA / TW - 1/4", 3/8" I.D.

- Designed to handle various lengths of oxygen/acetylene or T-grade twin line hose
- Double sealed, special molded o-rings prevent leakage
- Swivel inlets are both permanently identified with machined grooves on the gas side to assure proper installation



TW84100 OLPT



NOTE: TW7400 OLP(T), TW84000 OLPT, and TW86000 OLPT are listed to UL 1351

Size Index	Size Index					
	1		2		3	
	in	mm	in	mm	in	mm
A	20 1/4	514	20 1/4	514	25 3/8	645
B	19 3/4	502	19 3/4	502	24	610
C	7 7/8	200	7 7/8	200	10	254
D	3 7/8	98	3 7/8	98	6	152
E	7 3/8	187	8 1/2	216	12 1/4	311

Series TW5000 reels have four 5/16" (8 mm) diameter mounting holes.

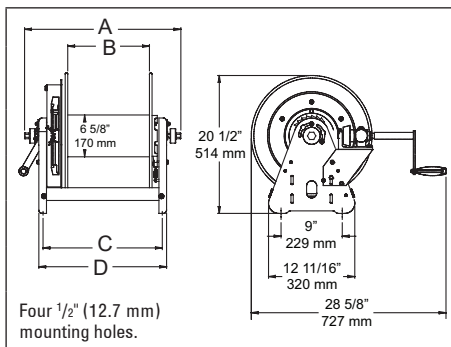

Size Index	Size Index			
	4		5	
	in	mm	in	mm
A	15 5/8	397	21 5/8	550
B	6	152	12	305
C	9 3/4	248	15 3/4	400
D	11	280	17	432

Length with crank handle removed is 17 3/4" (451 mm).

Dual swivel is an exclusive Reelcraft design

The aluminum dual swivel body is hard coated for wear resistance. This assures positive separation of gases due to its unique design. Available with Series TW5000, TW7000, and TWHD70000 reels.

Models with a ★ icon are our most popular models.

Model with hose & bumper	Shipping Weight		Hose I.D.		Hose O.D.		Hose Length		Max Pressure		Hose Outlet (F)		Reel Inlet		Reel Outlet (M)		Size Index #
	lbs	kg	in	mm	in	mm	ft	m	psi	bar	in	in	in	in	in		
Twin Line Welding Gas - Oxygen / Acetylene, Mapp, Propane, Natural, and Fuel Gas (T-Grade) Hose Reels																	
TW5425 OLPT	26	12	1/4	6	.530	13	25	8	200	14	9/16-18	1/4 NPT(F)	9/16-18			*	
TW7450 OLPT ★	50	23	1/4	6	.530	13	50	15	200	14	9/16-18	1/4 NPT(F)	9/16-18			1	
RSTW7450 OLPT	53		1/4	3	.530	13	50	15	200	14	9/16-18	1/4 NPT(F)	9/16-18			1	
TW7460 OLPT	55	25	1/4	6	.530	13	60	18	200	14	9/16-18	1/4 NPT(F)	9/16-18			1	
TWHD74085 OLPT	74	34	1/4	6	.530	13	85	26	200	14	9/16-18	1/4 NPT(F)	9/16-18			2	
TW84100 OLPT	101	46	1/4	6	.530	13	100	30	200	14	9/16-18	9/16-18(M)	9/16-18			3	
TW86050 OLPT	90	41	3/8	10	.625	16	50	15	200	14	9/16-18	9/16-18(M)	9/16-18			3	
TW86075 OLPT	99	45	3/8	10	.625	16	75	23	200	14	9/16-18	9/16-18(M)	9/16-18			3	

Acetylene and fuel gas (red) inlet 1/4" FPT / oxygen (green) inlet 1/4" FPT. 9/16-18 models above are B size. Acetylene/fuel gas side has a LH thread and the oxygen side has a RH thread. Maximum temperature 150 °F (65 °C). *See page 10 size index 1.

Model without hose & bumper	Shipping Weight		Hose Capacity			Max Pressure	Reel Inlet	Reel Outlet (M)	Size Index #				
	lbs	kg	I.D.	O.D.	Length								
	in	mm	in	mm	ft	m	psi	bar	in	in			
Twin Line Welding Gas - Oxygen / Acetylene, Mapp, Propane, Natural, and Fuel Gas (T-Grade) Hose Reels													
TW7400 OLPT	43	20	1/4	6	.530	13	60	18	200	14	1/4 NPT(F)	9/16-18	1
BA36106 LT*	50	23	1/4	6	.530	13	125	38	200	14	1/4 NPT(F)	9/16-18	4
BA36112 LT*	57	26	1/4	6	.530	13	250	76	200	14	1/4 NPT(F)	9/16-18	5
TW84000 OLPT	81	37	1/4	6	.530	13	100	30	200	14	9/16 - 18(M)	9/16-18	3
TW86000 OLPT	86	39	3/8	10	.625	16	75	23	200	14	9/16 - 18(M)	9/16-18	3

Maximum temperature 150 °F (65 °C). *Bevel crank model.

Inlet & Outlet Hoses
See page 31

Pivot Bases & Swing Brackets
See page 39

NEW!
Reel Covers
See page 36

Interactive Reel Catalog
Visit reelcraft.com/catalog for complete product specifications, parts, and accessories.